

## Class G – the ultimate amplifier technology - explained..... In simple terms!

First, some history: conventional Class A and Class AB design have good points and bad points

**Class A** – an inefficient solution to the class A/B crossover problem

**Pros** – does not suffer from crossover distortion and is often observed to be totally transparent for this reason offering a level of realism through low level accuracy that is seldom achieved in a class A/B design.

**Cons** – When used in a solely Class A design, it is wildly inefficient as it will always be drawing full power even with no signal to amplify, for this reason Class A amplifiers usually offer lower power outputs and is often found only in esoteric high-end designs.

**Class AB** – the most common amplifier design

**Pros** - Far more efficient than pure Class A

**Cons** - suffers from crossover distortion at low levels – remember the magic of audio reproduction is not the loud stuff rather it is the tiniest of details that create that sense of reality that we search for.

**Class G** – complex to design, but engineered correctly, the clever solution.

**Pros** – Greater efficiency and transparency, with less wasted heat energy.

**Cons** – Expensive to engineer and hard to perfect, hence seldom seen.

**Class A**

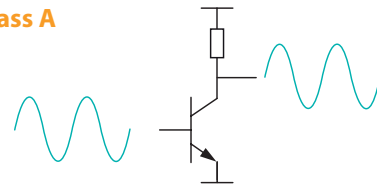

**Class AB**

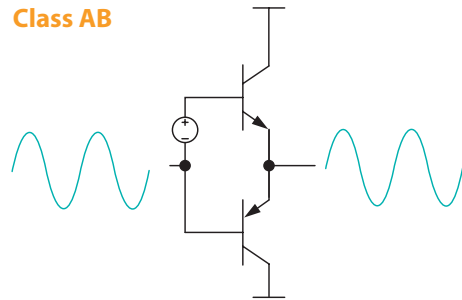

## What exactly is Class G?

Like a hybrid car engine, Class G implements multiple power supplies rather than just a single supply. If a dynamic signal is received that goes beyond the capability of this first power supply, the secondary supply is gradually brought in up to full rated power output as required. This gives a very efficient design as additional power is only used when required, much like a turbo-charger. Modern high speed silicon allows us to make this switch faster than would ever be required, even way beyond the audio bandwidth, so there is no “turbo lag”.

The first power supply is of lower power and within this region we run in pure Class A, which has no crossover distortion. As the secondary supply is only used when required, extreme levels of power are possible because very little energy is wasted in the amplifier as heat when it is not being used. Without control this power would be ill-used, so like high performance car tyres, multiple output devices within the amplifier keep a tight grip on the loudspeaker at all times, ensuring your listening experience never “leaves the road”.



**Class G**

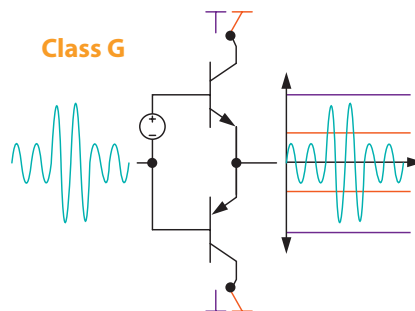

## Summary

Arcam has been investigating and perfecting Class G for many years and through intensive R&D we can bring an amplifier to market with no compromise, with absolute transparency and absolute power while retaining total control of the precious audio signal. Take an Arcam Class G amplifier for a test drive today!